



Unitywater

Serving you today,
investing in tomorrow.



Mr M F & Mrs M A Gillam
25 Somers St
CASHMERE QLD 4500

WATER AND SEWERAGE YOUR BILL

1300 086 489
Emergencies and faults 24 Hours, 7 days
Account enquiries 7am-6pm Mon-Fri
unitywater.com
ABN 89 791 717 472

Account number	99891072
Payment reference	0998 9107 23
Property	One On Slater, Unit 6/1 Slater Ave, LAWNTON, QLD

Bill number	7119021518
Billing period	02 Mar 2019 96 days to 5 Jun 2019
Issue date	10 Jun 2019
Approximate date of next meter reading	27 Aug 2019

Your account activity

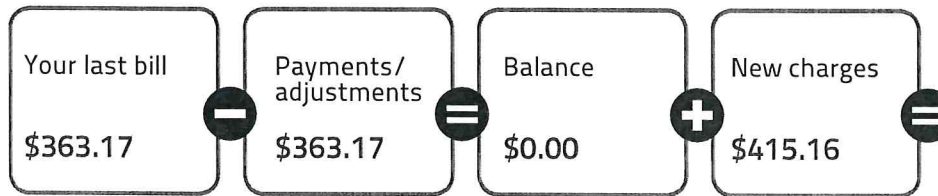

Direct debit is set up to pay the total due on the due date

Total due: **\$415.16**

Due date: **10 Jul 2019**

11% interest per annum, compounding daily, will apply to any amount not paid by the due date

Compare your average daily usage over time

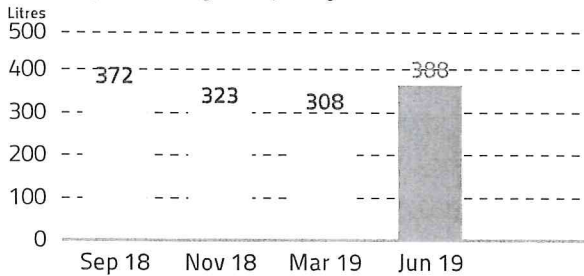

Compare your current daily usage with others in the Unitywater region

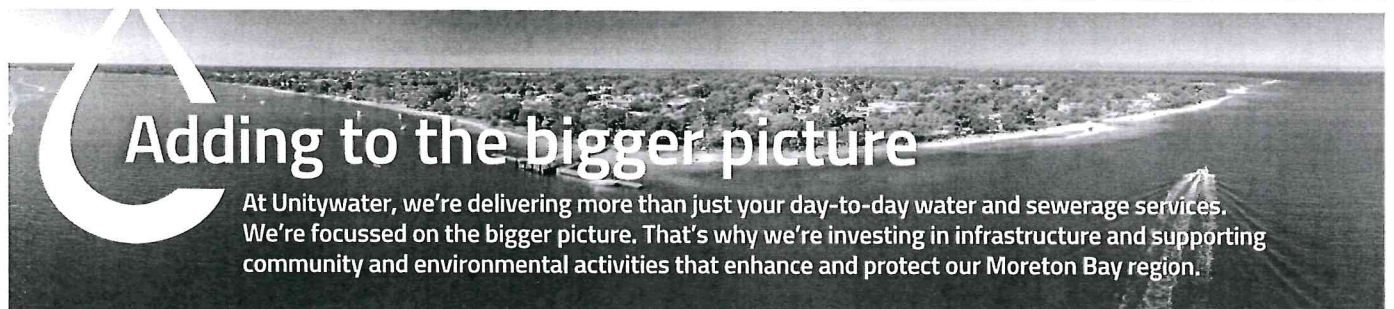
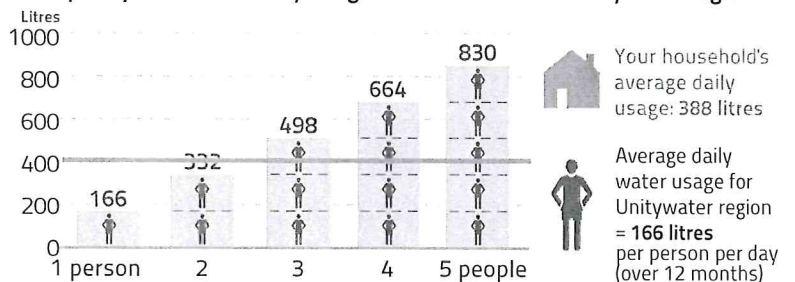

Adding to the bigger picture

At Unitywater, we're delivering more than just your day-to-day water and sewerage services. We're focussed on the bigger picture. That's why we're investing in infrastructure and supporting community and environmental activities that enhance and protect our Moreton Bay region.

Easy ways to pay For other payment options - see over



BPAY®
Bill Code: 130393
Ref: 0998 9107 23
Contact your bank or financial institution to pay from your cheque, savings, debit, credit card or transaction account. Find out more at bpay.com.au
© Registered to BPAY Pty Ltd ABN 69 079 137 518



Direct Debit
Login to My Account at unitywater.com to set up automatic payments from your bank account or credit card or call us for assistance.

SmoothPay

Smooth out your bill payments across the year with regular fortnightly or monthly payments, interest free. Find out more at unitywater.com/smoothpay



Unitywater

Serving you today,
investing in tomorrow.



Mr M F & Mrs M A Gillam
25 Somers St
CASHMERE QLD 4500



WATER AND SEWERAGE YOUR BILL

1300 086 489
Emergencies and faults 24 Hours, 7 days
Account enquiries 7am-6pm Mon-Fri
unitywater.com
ABN 89 791 717 472

Account number	99891072
Payment reference	0998 9107 23
Property	One On Slater, Unit 6/1 Slater Ave, LAWNTON, QLD

Bill number	7119352200
Billing period	06 Jun 2019 84 days to 28 Aug 2019
Issue date	3 Sep 2019
Approximate date of next meter reading	28 Nov 2019

Your account activity

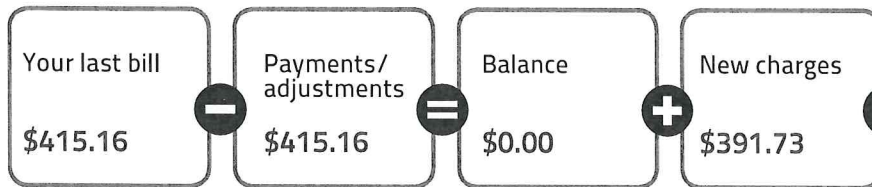

Direct debit is set up to pay the total due on the due date

Total due: **\$391.73**
 Due date: **3 Oct 2019**

8% interest per annum, compounding daily, will apply to any amount not paid by the due date

Compare your average daily usage over time

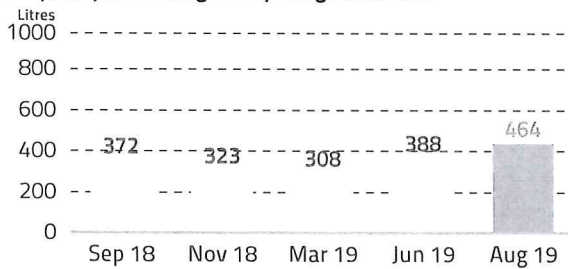

Compare your current daily usage with others in the Unitywater region

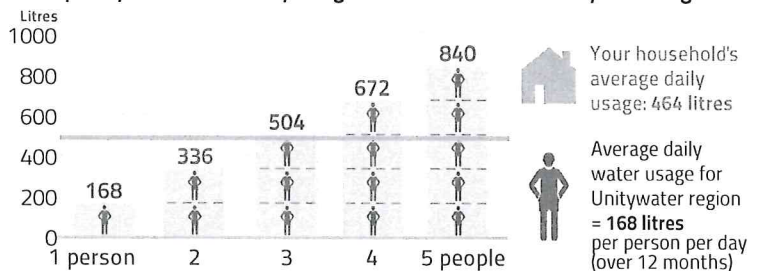

GET TO KNOW THE INS AND OUTS OF YOUR BILL

See inside for the full picture about 2019-20 water and sewerage prices and what these charges pay for.

Easy ways to pay For other payment options - see over

BPAY
 Biller Code: 130393
 Ref: 0998 9107 23
 Contact your bank or financial institution to pay from your cheque, savings, debit, credit card or transaction account.
 Find out more at bpay.com.au
 © Registered to BPAY Pty Ltd ABN 69 079 137 518

DIRECT DEBIT
 Direct Debit
 Login to My Account at unitywater.com to set up automatic payments from your bank account or credit card or call us for assistance.

SmoothPay
 Smooth out your bill payments across the year with regular fortnightly or monthly payments, interest free.
 Find out more at unitywater.com/smoothpay



Mr M F & Mrs M A Gillam
25 Somers St
CASHMERE QLD 4500

WATER AND SEWERAGE YOUR BILL

1300 086 489
Emergencies and faults 24 Hours, 7 days
Account enquiries 7am-6pm Mon-Fri

unitywater.com
ABN 89 791 717 472

Account number	99891072
Payment reference	0998 9107 23
Property	One On Slater, Unit 6/1 Slater Ave, LAWNTON, QLD

Bill number	7119678725
Billing period	29 Aug 2019 to 27 Nov 2019
Issue date	2 Dec 2019
Approximate date of next meter reading	26 Feb 2020

Your account activity

Your last bill \$391.73	−	Payments/ adjustments \$391.73	=	Balance \$0.00	+	New charges \$365.73	=	Total due \$365.73
								Due date 6 Jan 2020

Direct debit is set up to pay the total due on the due date

8% interest per annum, compounding daily, will apply to any amount not paid by the due date

Compare your average daily usage over time

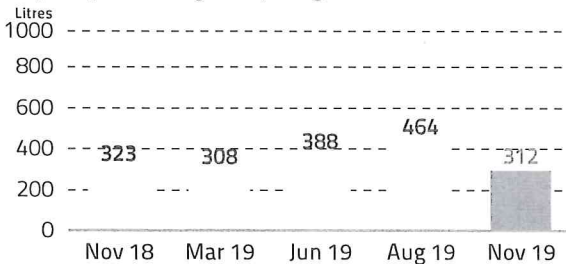

Compare your current daily usage with others in the Unitywater region

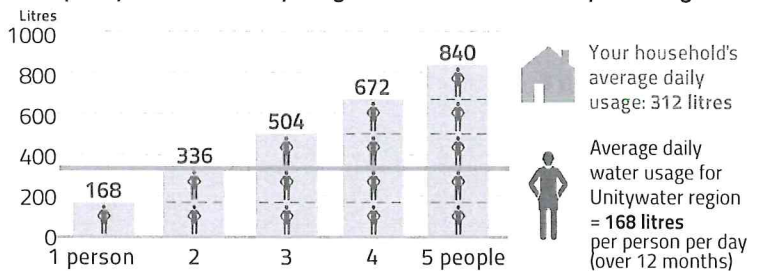

Count the Ways LET'S SAVE WATER TOGETHER

Our dam levels are dropping. Let's count on each other to make positive changes, like cutting your shower time to 4 minutes.

For personalised tips tailored to your home, visit unitywater.com/savewater

Easy ways to pay For other payment options - see over

BPAY[®]
Biller Code: 130393
Ref: 0998 9107 23

Contact your bank or financial institution to pay from your cheque, savings, debit, credit card or transaction account.
Find out more at bpay.com.au
© Registered to BPAY Pty Ltd ABN 69 079 137 518

DIRECT DEBIT

Direct Debit
Login to My Account at unitywater.com to set up automatic payments from your bank account or credit card or call us for assistance.

SmoothPay

Smooth out your bill payments across the year with regular fortnightly or monthly payments, interest free.
Find out more at unitywater.com/smoothpay



Unitywater

Serving you today,
investing in tomorrow.



Mr M F & Mrs M A Gillam
25 Somers St
CASHMERE QLD 4500

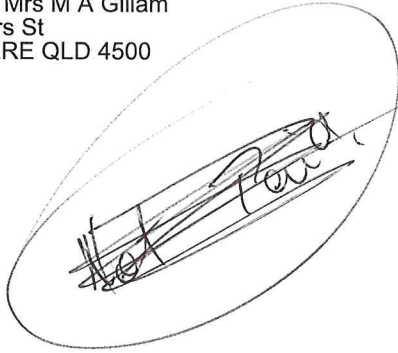

WATER AND SEWERAGE YOUR BILL

1300 086 489
Emergencies and faults 24 Hours, 7 days
Account enquiries 8am-5pm Mon-Fri

unitywater.com
ABN 89 791 717 472

Account number	99891072
Payment reference	0998 9107 23
Property	One On Slater, Unit 6/1 Slater Ave, LAWNTON, QLD

Bill number	7120012394
Billing period	28 Nov 2019 91 days to 26 Feb 2020
Issue date	4 Mar 2020
Approximate date of next meter reading	28 May 2020

Your account activity

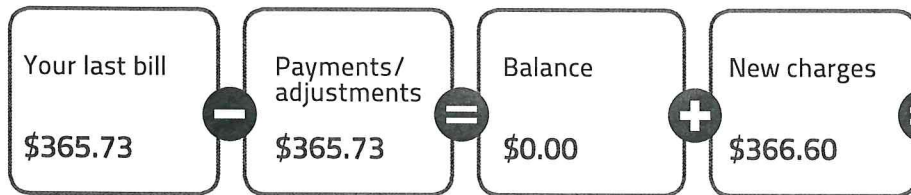

Direct debit is set up to pay the total due on the due date

Total due	\$366.60
Due date	3 Apr 2020

8% interest per annum, compounding daily, will apply to any amount not paid by the due date

Compare your average daily usage over time

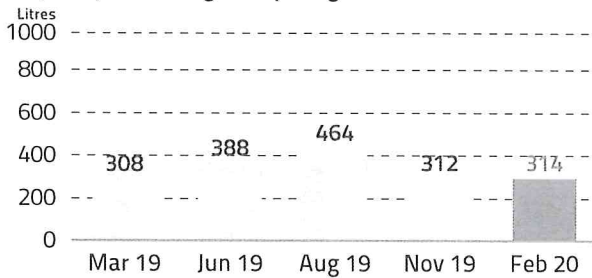

Compare your current daily usage with others in the Unitywater region

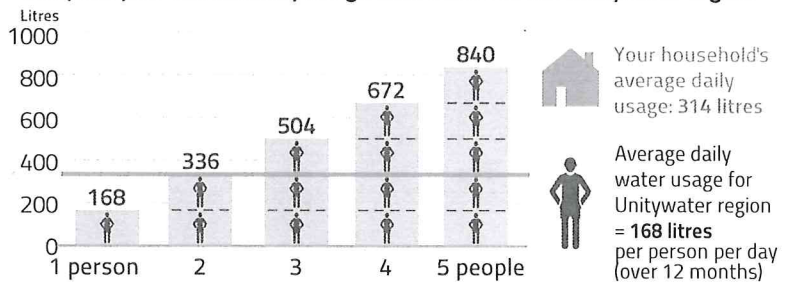

Count the Ways LET'S SAVE WATER TOGETHER

Our dam levels are dropping. Let's count on each other to make positive changes, like cutting your shower time to 4 minutes.

For personalised tips tailored to your home, visit unitywater.com/savewater

Easy ways to pay For other payment options - see over



BPAY[®]
Bill Code: 130393
Ref: 0998 9107 23
Contact your bank or financial institution to pay from your cheque, savings, debit, credit card or transaction account.
Find out more at bpay.com.au
© Registered to BPAY Pty Ltd ABN 69 079 137 518



Direct Debit
Login to My Account at unitywater.com to set up automatic payments from your bank account or credit card or call us for assistance.

SmoothPay

Smooth out your bill payments across the year with regular fortnightly or monthly payments, interest free.
Find out more at unitywater.com/smoothpay